

Addendum 5 of REQUEST FOR PROPOSAL



Shasta Regional Transportation Agency

1255 East Street
Suite 202
Redding, CA 96001

**Battery Electric Vehicle Procurement for
Salmon Runner and North Valley Feeder
Procurement No. 2019-01**

January 28, 2019

Addendum 5 of Procurement No. 2019-01 – Request for Proposal for Battery Electric Vehicle Procurement for Salmon Runner and North Valley Feeder – involves the Agency’s responses to Requests for Pre-Offer Change or Approved Equal.

Request for Proposal
January 16, 2019
Procurement No. 2019-01

CER 2. Request for Pre-Offer Change or Approved Equal

This form must be used for requested clarifications, changes, substitutes or approval of items equal to items specified with a brand name and must be submitted as far in advance of the Due Date, as specified in “Questions, Clarifications and Omissions.”

**Shasta Regional Transportation Agency
Procurement No. 2019-01
Battery Electric Vehicle Procurement for Salmon Runner and North Valley Feeder**

Request #: 1 Proposer: Motor Coach Industries. RFP Section: TS 5.3 Service Life Page: 69	
Questions/clarification or approved equal: MCI’s commuter coach is classified as a heavy duty bus. As such the coach is tested to a useful life of 500,000 miles or 12 years. However, many customers operate MCI commuter coaches in excess of 12 years and 500,000 miles.	
Agency action:	<input type="checkbox"/> Approved <input type="checkbox"/> Denied <input type="checkbox"/> See addendum <input checked="" type="checkbox"/> See response below
Agency response: Received as information. Please submit deviation request on form CER 5 with proposal submittal if the design life of the proposed coach does not meet the design life specified in TS 5.3.	

CER 2. Request for Pre-Offer Change or Approved Equal

This form must be used for requested clarifications, changes, substitutes or approval of items equal to items specified with a brand name and must be submitted as far in advance of the Due Date, as specified in "Questions, Clarifications and Omissions."

**Shasta Regional Transportation Agency
Procurement No. 2019-01
Battery Electric Vehicle Procurement for Salmon Runner and North Valley Feeder**

Request #: 2	
Proposer: Motor Coach Industries.	
RFP Section: TS 5.7 Operating Environment	
Page: 71	
Questions/clarification or approved equal: MCI shall minimize the degradation of performance due to atmospheric conditions at temperatures below 15 degrees F and above 120 degrees F. Currently there is no test data for operating the coach above altitudes of 3000 FT	
Agency action:	<input type="checkbox"/> Approved <input type="checkbox"/> Denied <input type="checkbox"/> See addendum <input checked="" type="checkbox"/> See response below
Agency response: Received as information.	

CER 2. Request for Pre-Offer Change or Approved Equal

This form must be used for requested clarifications, changes, substitutes or approval of items equal to items specified with a brand name and must be submitted as far in advance of the Due Date, as specified in “Questions, Clarifications and Omissions.”

**Shasta Regional Transportation Agency
 Procurement No. 2019-01
 Battery Electric Vehicle Procurement for Salmon Runner and North Valley Feeder**

Request #: 3 Proposer: Motor Coach Industries. RFP Section: TS 6.6 Ramp Clearances Page: 74	
Questions/clarification or approved equal: MCI's D45 CRT coach is designed with an approach angle of 8 degrees and a departure angle of 6 degrees in lieu of the approach and departure angle of 8.6 degrees.	
Agency action:	<input type="checkbox"/> Approved <input type="checkbox"/> Denied <input type="checkbox"/> See addendum <input checked="" type="checkbox"/> See response below
Agency response: Received as information. Please submit deviation request on form CER 5 with proposal submittal if the proposed coach does not meet the approach and departure angles specified in TS 6.6.	

CER 2. Request for Pre-Offer Change or Approved Equal

This form must be used for requested clarifications, changes, substitutes or approval of items equal to items specified with a brand name and must be submitted as far in advance of the Due Date, as specified in “Questions, Clarifications and Omissions.”

**Shasta Regional Transportation Agency
 Procurement No. 2019-01
 Battery Electric Vehicle Procurement for Salmon Runner and North Valley Feeder**

Request #: 4 Proposer: Motor Coach Industries. RFP Section: TS 6.7 Ground Clearance Page: 74	
Questions/clarification or approved equal: MCI respectfully requests that this section be removed in its entirety as this appears to be applicable to a transit bus rather than an over the road coach.	
Agency action:	<input type="checkbox"/> Approved X Denied <input type="checkbox"/> See addendum X See response below
Agency response: Request denied. Please submit deviation request on form CER 5 with proposal submittal if the proposed coach does not meet the ground clearance specified in TS 6.7.	

CER 2. Request for Pre-Offer Change or Approved Equal

This form must be used for requested clarifications, changes, substitutes or approval of items equal to items specified with a brand name and must be submitted as far in advance of the Due Date, as specified in “Questions, Clarifications and Omissions.”

**Shasta Regional Transportation Agency
 Procurement No. 2019-01
 Battery Electric Vehicle Procurement for Salmon Runner and North Valley Feeder**

Request #: 5 Proposer: Motor Coach Industries. RFP Section: TS 8.2 Agency Design Operating Profile (Battery Electric Bus) Page: 76	
Questions/clarification or approved equal: MCI requests further review for the operating profile of the proposed routes. We recommend that, due to the risk of degradation of batteries over time and the associated decrease range, Shasta evaluate the potential of an on-route charging strategy.	
Agency action:	<input type="checkbox"/> Approved <input type="checkbox"/> Denied <input type="checkbox"/> See addendum <input checked="" type="checkbox"/> See response below
Agency response: Received as information. Please refer to <i>Section NR 1. Description of the Work to be Done</i> and <i>Section TS 8.2 Agency Design Operating Profile</i> . The Agency expects to have charging stations located in Sacramento, Redding, and Willows, CA and to charge the coaches overnight and midday between scheduled trips, as necessary.	

CER 2. Request for Pre-Offer Change or Approved Equal

This form must be used for requested clarifications, changes, substitutes or approval of items equal to items specified with a brand name and must be submitted as far in advance of the Due Date, as specified in “Questions, Clarifications and Omissions.”

**Shasta Regional Transportation Agency
Procurement No. 2019-01
Battery Electric Vehicle Procurement for Salmon Runner and North Valley Feeder**

Request #: 6	
Proposer: Motor Coach Industries.	
RFP Section: TS 9.3.5 Energy Storage System and Controller	
Page: 82	
Questions/clarification or approved equal: Per paragraph 5 on page 82, MCI can, in partnership with its battery supplier, MCI can provide the testing data. However, testing from an independent third party is not currently available. MCI requests testing data be accepted in lieu of an independent third party.	
Agency action:	<input checked="" type="checkbox"/> Approved <input type="checkbox"/> Denied <input type="checkbox"/> See addendum <input checked="" type="checkbox"/> See response below
Agency response: SRTA shall consider testing data from a non-independent source. However, such data shall be scored lower during the evaluation than testing data provided by an independent source.	

CER 2. Request for Pre-Offer Change or Approved Equal

This form must be used for requested clarifications, changes, substitutes or approval of items equal to items specified with a brand name and must be submitted as far in advance of the Due Date, as specified in “Questions, Clarifications and Omissions.”

**Shasta Regional Transportation Agency
 Procurement No. 2019-01
 Battery Electric Vehicle Procurement for Salmon Runner and North Valley Feeder**

Request #: 7	
Proposer: Motor Coach Industries.	
RFP Section: TS 9.3.5 Energy Storage System and Controller (Battery Charging)	
Page: 84	
Questions/clarification or approved equal: MCI does not currently off an inverted pantograph overhead charging system. While such a system may be developed at a later date, we request the mandatory requirement this be offered as an option be deleted.	
Agency action:	<input type="checkbox"/> Approved <input type="checkbox"/> Denied <input type="checkbox"/> See addendum <input checked="" type="checkbox"/> See response below
Agency response: The inverted pantograph is not a mandatory requirement. SRTA requests optional pricing to equip the coach to accept charge via an overhead inverted pantograph charging system. If the bidder cannot provide optional pricing, please indicate “Not Available” on the pricing sheet.	

CER 2. Request for Pre-Offer Change or Approved Equal

This form must be used for requested clarifications, changes, substitutes or approval of items equal to items specified with a brand name and must be submitted as far in advance of the Due Date, as specified in “Questions, Clarifications and Omissions.”

**Shasta Regional Transportation Agency
 Procurement No. 2019-01
 Battery Electric Vehicle Procurement for Salmon Runner and North Valley Feeder**

Request #: 8 Proposer: Motor Coach Industries. RFP Section: TS 9.3.6 Propulsion System Controller (PSC) Page: 85	
Questions/clarification or approved equal: MCI is currently confirming with battery vendor that they follow this standard. MCI will advise Shasta RTA when this information becomes available.	
Agency action:	<input type="checkbox"/> Approved <input type="checkbox"/> Denied <input type="checkbox"/> See addendum <input checked="" type="checkbox"/> See response below
Agency response: Received as information.	

CER 2. Request for Pre-Offer Change or Approved Equal

This form must be used for requested clarifications, changes, substitutes or approval of items equal to items specified with a brand name and must be submitted as far in advance of the Due Date, as specified in “Questions, Clarifications and Omissions.”

**Shasta Regional Transportation Agency
 Procurement No. 2019-01
 Battery Electric Vehicle Procurement for Salmon Runner and North Valley Feeder**

Request #: 9	
Proposer: Motor Coach Industries.	
RFP Section: TS 11. Transmission	
Page: 87	
Questions/clarification or approved equal: The requirement for a transmission is a requirement for a diesel or CNG coach. An electric over the road coach will not include a transmission and we request this reference be deleted.	
Agency action:	<input type="checkbox"/> Approved <input type="checkbox"/> Denied <input type="checkbox"/> See addendum <input checked="" type="checkbox"/> See response below
Agency response: The requirements stated in <i>TS 11 Transmission</i> are applicable to those electric drive systems that include a transmission. Bidders that propose a design that excludes a transmission should indicate “Not Applicable.”	

CER 2. Request for Pre-Offer Change or Approved Equal

This form must be used for requested clarifications, changes, substitutes or approval of items equal to items specified with a brand name and must be submitted as far in advance of the Due Date, as specified in “Questions, Clarifications and Omissions.”

Shasta Regional Transportation Agency
Procurement No. 2019-01
Battery Electric Vehicle Procurement for Salmon Runner and North Valley Feeder

Request #: 10	
Proposer: Motor Coach Industries.	
RFP Section: TS 23.1 Propulsion Compartment Bulkheads	
Page: 91	
Questions/clarification or approved equal: MCI's coaches are designed to meet all FMVSS regulations. FMVSS 302 is the equivalent section to FTA Docket 90A. MCI requests Shasta change this section to meet FMVSS 302 rather than FTA Docket 90A.	
Agency action:	<input checked="" type="checkbox"/> Approved <input type="checkbox"/> Denied <input type="checkbox"/> See addendum <input checked="" type="checkbox"/> See response below
Agency response: Approved. Compliance with FMVSS 302 is required. Compliance with FTA Docket 90A is not required.	

CER 2. Request for Pre-Offer Change or Approved Equal

This form must be used for requested clarifications, changes, substitutes or approval of items equal to items specified with a brand name and must be submitted as far in advance of the Due Date, as specified in “Questions, Clarifications and Omissions.”

Shasta Regional Transportation Agency
Procurement No. 2019-01
Battery Electric Vehicle Procurement for Salmon Runner and North Valley Feeder

Request #: 11	
Proposer: Motor Coach Industries.	
RFP Section: TS 23.2 Crash Worthiness	
Page: 91	
Questions/clarification or approved equal: MCI believes this crash worthiness test is not for an over-the-road high floor coach and request this section be removed.	
Agency action:	<input type="checkbox"/> Approved <input type="checkbox"/> Denied <input type="checkbox"/> See addendum <input checked="" type="checkbox"/> See response below
Agency response: Proposed coaches are required to meet all applicable federal and state regulations that specify design, construction, performance, and durability requirements of the coach, such as but not limited to FMVSS. The crashworthiness requirements specified in TS 23.2 are not required; however, proposed coaches that do not meet TS 23.2 will be scored lower during the evaluation than coaches that do. Within its proposal submittal, each bidder must describe the crashworthiness of the proposed coach, safety features that minimize the probability and/or severity of a crash, and state whether the proposed coach meets TS 23.2.	

CER 2. Request for Pre-Offer Change or Approved Equal

This form must be used for requested clarifications, changes, substitutes or approval of items equal to items specified with a brand name and must be submitted as far in advance of the Due Date, as specified in “Questions, Clarifications and Omissions.”

**Shasta Regional Transportation Agency
 Procurement No. 2019-01
 Battery Electric Vehicle Procurement for Salmon Runner and North Valley Feeder**

Request #: 12	
Proposer: Motor Coach Industries.	
RFP Section: TS 33.2 Steering and Tag Axles (Commuter Coach)	
Page: 98	
Questions/clarification or approved equal: MCI's coaches are designed with an independent front suspension and steerable tag axle in lieu of a solid beam design.	
Agency action:	<input checked="" type="checkbox"/> Approved <input type="checkbox"/> Denied <input type="checkbox"/> See addendum <input checked="" type="checkbox"/> See response below
Agency response: Independent front suspension is an approved alternative to a solid beam design.	

CER 2. Request for Pre-Offer Change or Approved Equal

This form must be used for requested clarifications, changes, substitutes or approval of items equal to items specified with a brand name and must be submitted as far in advance of the Due Date, as specified in “Questions, Clarifications and Omissions.”

**Shasta Regional Transportation Agency
 Procurement No. 2019-01
 Battery Electric Vehicle Procurement for Salmon Runner and North Valley Feeder**

Request #: 13 Proposer: Motor Coach Industries. RFP Section: TS 33.3.4 Steering Wheel Telescopic Adjustment Page: 99	
Questions/clarification or approved equal: MCI's steering wheel design provides an angle from 0 to 21 degrees, and a height adjustment from 32 inches to 30 inches at minimum telescopic, and from 34 inches to 32 inches at maximum telescopic.	
Agency action:	<input type="checkbox"/> Approved <input type="checkbox"/> Denied <input type="checkbox"/> See addendum <input checked="" type="checkbox"/> See response below
Agency response: Received as information. Please submit deviation request on form CER 5 with proposal submittal if the proposed coach does not meet TS 33.3.4.	

CER 2. Request for Pre-Offer Change or Approved Equal

This form must be used for requested clarifications, changes, substitutes or approval of items equal to items specified with a brand name and must be submitted as far in advance of the Due Date, as specified in “Questions, Clarifications and Omissions.”

**Shasta Regional Transportation Agency
 Procurement No. 2019-01
 Battery Electric Vehicle Procurement for Salmon Runner and North Valley Feeder**

Request #: 14	
Proposer: Motor Coach Industries.	
RFP Section: TS 39.2 Air Compressor	
Page: 103	
Questions/clarification or approved equal: MCI's air compressor is driven by an electric motor and will build pressure from 0 to 130 psi in under 3 minutes.	
Agency action:	<input type="checkbox"/> Approved <input type="checkbox"/> Denied <input type="checkbox"/> See addendum <input checked="" type="checkbox"/> See response below
Agency response: An air compressor driven by an electric motor that builds pressure from 0 to 130 psi in under 3 minutes is approved as an approved equal to the compressor described in TS 39.2.	

CER 2. Request for Pre-Offer Change or Approved Equal

This form must be used for requested clarifications, changes, substitutes or approval of items equal to items specified with a brand name and must be submitted as far in advance of the Due Date, as specified in “Questions, Clarifications and Omissions.”

**Shasta Regional Transportation Agency
 Procurement No. 2019-01
 Battery Electric Vehicle Procurement for Salmon Runner and North Valley Feeder**

Request #: 15	
Proposer: Motor Coach Industries.	
RFP Section: TS 45.2.2 Programmability (Software)	
Page: 112	
Questions/clarification or approved equal: MCI designs its coaches to optimize drivability and performance. As such the ability for customers to change the programming is restricted. MCI requests this section be deleted	
Agency action:	<input checked="" type="checkbox"/> Approved <input type="checkbox"/> Denied <input type="checkbox"/> See addendum <input checked="" type="checkbox"/> See response below
Agency response: Approved. Software for the drivetrain level components does not need to be programmable by the Agency.	

CER 2. Request for Pre-Offer Change or Approved Equal

This form must be used for requested clarifications, changes, substitutes or approval of items equal to items specified with a brand name and must be submitted as far in advance of the Due Date, as specified in “Questions, Clarifications and Omissions.”

Shasta Regional Transportation Agency
Procurement No. 2019-01
Battery Electric Vehicle Procurement for Salmon Runner and North Valley Feeder

Request #: 16	
Proposer: Motor Coach Industries.	
RFP Section: TS 52. Driver’s Side Window	
Page: 124	
Questions/clarification or approved equal: MCI wishes to clarify that the driver’s side window is bonded. However, it is easily replaceable with an estimated repair time of between 2 and 4 hours.	
Agency action:	<input type="checkbox"/> Approved <input type="checkbox"/> Denied <input type="checkbox"/> See addendum <input checked="" type="checkbox"/> See response below
Agency response: Provide a description of the replacement procedure and any equipment and tools required within the proposal submittal. Maintainability is a scored criterion during evaluation.	

CER 2. Request for Pre-Offer Change or Approved Equal

This form must be used for requested clarifications, changes, substitutes or approval of items equal to items specified with a brand name and must be submitted as far in advance of the Due Date, as specified in “Questions, Clarifications and Omissions.”

**Shasta Regional Transportation Agency
 Procurement No. 2019-01
 Battery Electric Vehicle Procurement for Salmon Runner and North Valley Feeder**

Request #: 17 Proposer: Motor Coach Industries. RFP Section: TS 58. HVAC Roof Ventilators Page: 128	
Questions/clarification or approved equal: MCI's coaches are designed with two roof escape/roof ventilators in lieu of one. MCI respectfully requests this section be modified to allow for two roof hatches/roof ventilators.	
Agency action:	<input checked="" type="checkbox"/> Approved <input type="checkbox"/> Denied <input type="checkbox"/> See addendum <input checked="" type="checkbox"/> See response below
Agency response: More than one roof escape/roof ventilators is approved.	

CER 2. Request for Pre-Offer Change or Approved Equal

This form must be used for requested clarifications, changes, substitutes or approval of items equal to items specified with a brand name and must be submitted as far in advance of the Due Date, as specified in “Questions, Clarifications and Omissions.”

**Shasta Regional Transportation Agency
 Procurement No. 2019-01
 Battery Electric Vehicle Procurement for Salmon Runner and North Valley Feeder**

Request #: 18 Proposer: Motor Coach Industries. RFP Section: TS 67. Fender Skirts Page: 130	
Questions/clarification or approved equal: MCI's design is based on a fiberglass fender skirt in lieu of a flexible material. MCI requests approval of this design.	
Agency action:	<input type="checkbox"/> Approved <input type="checkbox"/> Denied <input type="checkbox"/> See addendum <input checked="" type="checkbox"/> See response below
Agency response: SRTA shall consider alternate design. However, alternate design may be evaluated lower than requested design. Bidder shall provide comparative estimate to repair/replace fender skirt.	

CER 2. Request for Pre-Offer Change or Approved Equal

This form must be used for requested clarifications, changes, substitutes or approval of items equal to items specified with a brand name and must be submitted as far in advance of the Due Date, as specified in “Questions, Clarifications and Omissions.”

**Shasta Regional Transportation Agency
 Procurement No. 2019-01
 Battery Electric Vehicle Procurement for Salmon Runner and North Valley Feeder**

Request #: 19	
Proposer: Motor Coach Industries.	
RFP Section: TS 70.2 Front Bumper	
Page: 131	
Questions/clarification or approved equal: MCI's bumper material is corrosion-resistant and has energy absorbing capabilities which can withstand repeated impacts without sustaining damage. We request this section be changed from a requirement of 5 mph to a 2.5mph which is applicable to over the road coaches.	
Agency action:	<input type="checkbox"/> Approved <input type="checkbox"/> Denied <input type="checkbox"/> See addendum <input checked="" type="checkbox"/> See response below
Agency response: SRTA shall consider alternate design. However, alternate design may be evaluated lower than requested design. Bidder shall provide a description of the front bumper replacement procedure and any equipment and materials required within its proposal submittal.	

CER 2. Request for Pre-Offer Change or Approved Equal

This form must be used for requested clarifications, changes, substitutes or approval of items equal to items specified with a brand name and must be submitted as far in advance of the Due Date, as specified in “Questions, Clarifications and Omissions.”

**Shasta Regional Transportation Agency
 Procurement No. 2019-01
 Battery Electric Vehicle Procurement for Salmon Runner and North Valley Feeder**

Request #: 20 Proposer: Motor Coach Industries. RFP Section: TS 70.3 Rear Bumper Page: 132	
Questions/clarification or approved equal: MCI's bumper material is corrosion-resistant and has energy absorbing capabilities which can withstand repeated impacts without sustaining damage. We request this section be changed from a requirement of 5 mph to a 2.5mph which is applicable to over the road coaches.	
Agency action:	<input type="checkbox"/> Approved <input type="checkbox"/> Denied <input type="checkbox"/> See addendum <input checked="" type="checkbox"/> See response below
Agency response: SRTA shall consider alternate design. However, alternate design may be evaluated lower than requested design. Bidder shall provide a description of the front bumper replacement procedure and any equipment and materials required within its proposal submittal.	

CER 2. Request for Pre-Offer Change or Approved Equal

This form must be used for requested clarifications, changes, substitutes or approval of items equal to items specified with a brand name and must be submitted as far in advance of the Due Date, as specified in “Questions, Clarifications and Omissions.”

**Shasta Regional Transportation Agency
 Procurement No. 2019-01
 Battery Electric Vehicle Procurement for Salmon Runner and North Valley Feeder**

Request #: 21 Proposer: Motor Coach Industries. RFP Section: TS 75.13 Seating Area Lighting Page: 138	
Questions/clarification or approved equal: For improved durability, MCI provides fixed LED reading lights rather than adjustable. MCI requests approval of this design.	
Agency action:	<input checked="" type="checkbox"/> Approved <input type="checkbox"/> Denied <input type="checkbox"/> See addendum <input type="checkbox"/> See response below
Agency response: Approved.	

CER 2. Request for Pre-Offer Change or Approved Equal

This form must be used for requested clarifications, changes, substitutes or approval of items equal to items specified with a brand name and must be submitted as far in advance of the Due Date, as specified in “Questions, Clarifications and Omissions.”

**Shasta Regional Transportation Agency
 Procurement No. 2019-01
 Battery Electric Vehicle Procurement for Salmon Runner and North Valley Feeder**

Request #: 22 Proposer: Motor Coach Industries. RFP Section: TS 80.5 Door Glazing Page: 143	
Questions/clarification or approved equal: MCI's proposal is based on providing door glazing that is bonded in place. Zip type rubber is not available and cannot be provided. MCI requests approval of this design.	
Agency action:	<input type="checkbox"/> Approved <input type="checkbox"/> Denied <input type="checkbox"/> See addendum X See response below
Agency response: SRTA shall consider alternate design. However, alternate design may be evaluated lower than requested design. If the proposed coach utilizes door glazing that is bonded in place, provide a description of the repair procedure within the proposal submittal.	

CER 2. Request for Pre-Offer Change or Approved Equal

This form must be used for requested clarifications, changes, substitutes or approval of items equal to items specified with a brand name and must be submitted as far in advance of the Due Date, as specified in “Questions, Clarifications and Omissions.”

**Shasta Regional Transportation Agency
 Procurement No. 2019-01
 Battery Electric Vehicle Procurement for Salmon Runner and North Valley Feeder**

Request #: 23 Proposer: Motor Coach Industries. RFP Section: TS 82.2 Lift Door Page: 147	
Questions/clarification or approved equal: MCI's design includes a sliding lift door that slides to the front of the coach instead of the rear. MCI requests approval of either a forward or rear sliding design.	
Agency action:	<input checked="" type="checkbox"/> Approved <input type="checkbox"/> Denied <input type="checkbox"/> See addendum <input type="checkbox"/> See response below
Agency response: Approved.	

CER 2. Request for Pre-Offer Change or Approved Equal

This form must be used for requested clarifications, changes, substitutes or approval of items equal to items specified with a brand name and must be submitted as far in advance of the Due Date, as specified in “Questions, Clarifications and Omissions.”

**Shasta Regional Transportation Agency
Procurement No. 2019-01
Battery Electric Vehicle Procurement for Salmon Runner and North Valley Feeder**

Request #: 24	
Proposer: Motor Coach Industries.	
RFP Section: TS 87. Event Data Recorder (EDR)	
Page: 151	
Questions/clarification or approved equal: MCI requests Shasta provide the manufacture name and model number of its preferred EDR.	
Agency action:	<input type="checkbox"/> Approved <input type="checkbox"/> See addendum
	<input type="checkbox"/> Denied <input checked="" type="checkbox"/> See response below
Agency response: SRTA does not have a preferred EDT. Bidders are encouraged to recommend an EDR. If the bidder proposes multiple EDR options, then a description (design, features, cost, etc.) of each option must be provided within the proposal submittal.	

CER 2. Request for Pre-Offer Change or Approved Equal

This form must be used for requested clarifications, changes, substitutes or approval of items equal to items specified with a brand name and must be submitted as far in advance of the Due Date, as specified in “Questions, Clarifications and Omissions.”

**Shasta Regional Transportation Agency
 Procurement No. 2019-01
 Battery Electric Vehicle Procurement for Salmon Runner and North Valley Feeder**

Request #: 25 Proposer: Motor Coach Industries. RFP Section: TS 89.2 Bicycle Racks Page: 152	
Questions/clarification or approved equal: MCI can offer bicycle racks mounted in the rear or front bumper. MCI is unfamiliar with bicycle racks in the interior of the coach. MCI requests for the manufacture and model number of interior bike racks to determine feasibility.	
Agency action:	<input type="checkbox"/> Approved <input type="checkbox"/> Denied <input type="checkbox"/> See addendum <input checked="" type="checkbox"/> See response below
Agency response: SRTA requires the ability to safely and easily store up to four bikes. Bicycle storage must be secure and minimize damage to bicycles. The process to load bicycles must be easy and safe for passengers and driver. SRTA also requires luggage storage. While interior bicycle racks are preferred, it is not required. SRTA requests bidders propose a solution for bicycles and luggage that best meets SRTA's requirements.	

CER 2. Request for Pre-Offer Change or Approved Equal

This form must be used for requested clarifications, changes, substitutes or approval of items equal to items specified with a brand name and must be submitted as far in advance of the Due Date, as specified in “Questions, Clarifications and Omissions.”

**Shasta Regional Transportation Agency
 Procurement No. 2019-01
 Battery Electric Vehicle Procurement for Salmon Runner and North Valley Feeder**

Request #: 26	
Proposer: Motor Coach Industries.	
RFP Section: TS 90.2 Active Collision Avoidance and Mitigation System	
Page: 152	
Questions/clarification or approved equal: MCI would like to state that the “Active Collision Avoidance and Mitigation System” as described in section TS90.2 is not currently available. MCI offers an active collision avoidance system which is will be described in our proposal.	
Agency action:	<input type="checkbox"/> Approved <input type="checkbox"/> Denied <input type="checkbox"/> See addendum <input checked="" type="checkbox"/> See response below
Agency response: Received as information.	

CER 2. Request for Pre-Offer Change or Approved Equal

This form must be used for requested clarifications, changes, substitutes or approval of items equal to items specified with a brand name and must be submitted as far in advance of the Due Date, as specified in “Questions, Clarifications and Omissions.”

Shasta Regional Transportation Agency

Procurement No. 2019-01

Battery Electric Vehicle Procurement for Salmon Runner and North Valley Feeder

Request #: 27	
Proposer: Motor Coach Industries.	
RFP Section: CER 12. Minimum Milestone Plan	
Page: 221	
Questions/clarification or approved equal: Based on MCI's analysis of Shasta's requirements, which include deployment of charging infrastructure, and delivery of the last coach of October 10, 2019, MCI does not believe the timeline is achievable. MCI respectfully requests Shasta extend its schedule by six months to one year. Doing so should permit deployment and commissioning of charging infrastructure.	
Agency action:	<input type="checkbox"/> Approved <input type="checkbox"/> See addendum
	<input type="checkbox"/> Denied <input checked="" type="checkbox"/> See response below
Agency response: SRTA will accept proposals that meet the requested timeline. However, proposals that cannot meet the requested timeline will be scored lower than those that do meet the requested timeline.	

CER 2. Request for Pre-Offer Change or Approved Equal

This form must be used for requested clarifications, changes, substitutes or approval of items equal to items specified with a brand name and must be submitted as far in advance of the Due Date, as specified in “Questions, Clarifications and Omissions.”

**Shasta Regional Transportation Agency
 Procurement No. 2019-01
 Battery Electric Vehicle Procurement for Salmon Runner and North Valley Feeder**

Request #: 28 Proposer: Motor Coach Industries. RFP Section: SP 6 Liquidated Damages Page 51	
Questions/clarification or approved equal: This section requires liquidated damages of \$8,800 per calendar day. This amount is well above industry accepted standards. MCI requests liquidated damages of \$100 per business day.	
Agency action:	<input type="checkbox"/> Approved X Denied <input type="checkbox"/> See addendum X See response below
Agency response: The agency changes the last sentence of page 51 related to RFP Section SP 6 Liquidated Damages for Late Delivery to read as follows, “...the amount of such damages due to the Agency shall be fixed at \$500 per bus per calendar day not delivered and accepted by the Agency.	

CER 2. Request for Pre-Offer Change or Approved Equal

This form must be used for requested clarifications, changes, substitutes or approval of items equal to items specified with a brand name and must be submitted as far in advance of the Due Date, as specified in “Questions, Clarifications and Omissions.”

**Shasta Regional Transportation Agency
 Procurement No. 2019-01
 Battery Electric Vehicle Procurement for Salmon Runner and North Valley Feeder**

Request #: 29 Proposer: Motor Coach Industries. RFP Section: N/A	
Questions/clarification or approved equal: The RFP documents reflect the result of significant effort by Shasta to produce an RFP containing the detail applicable for such a procurement. As evidenced from the number of approved equals submitted, MCI requests an extension to the due date of one month, to April 4, 2019. This will allow MCI to prepare a response maximizing the benefit to Shasta.	
Agency action:	<input type="checkbox"/> Approved X Denied <input type="checkbox"/> See addendum <input type="checkbox"/> See response below
Agency response:	

CER 2. Request for Pre-Offer Change or Approved Equal

This form must be used for requested clarifications, changes, substitutes or approval of items equal to items specified with a brand name and must be submitted as far in advance of the Due Date, as specified in "Questions, Clarifications and Omissions."

Shasta Regional Transportation Agency
Procurement No. 2019-01
Battery Electric Vehicle Procurement for Salmon Runner and North Valley Feeder

Request #: 01	
Proposer: ABC Bus, Inc.	
RFP Section: TS 80 Passenger Doors	
Page: 142 & 143	
<p>Questions/clarification or approved equal:</p> <p>Would you accept an air operated out-swinging thin profile design entrance door of 1 panel featuring a thin seal sensitive edge on door with built up weather stripping on the frame in front axle on RHS of coach with exterior electrical metal (stainless steel) operation knob including outside key lock and additional grab handle on the entrance door mechanism (see attached description).</p>	
Agency action:	<input checked="" type="checkbox"/> Approved <input type="checkbox"/> Denied <input type="checkbox"/> See addendum <input type="checkbox"/> See response below
Agency response:	

Passenger door 1: construction

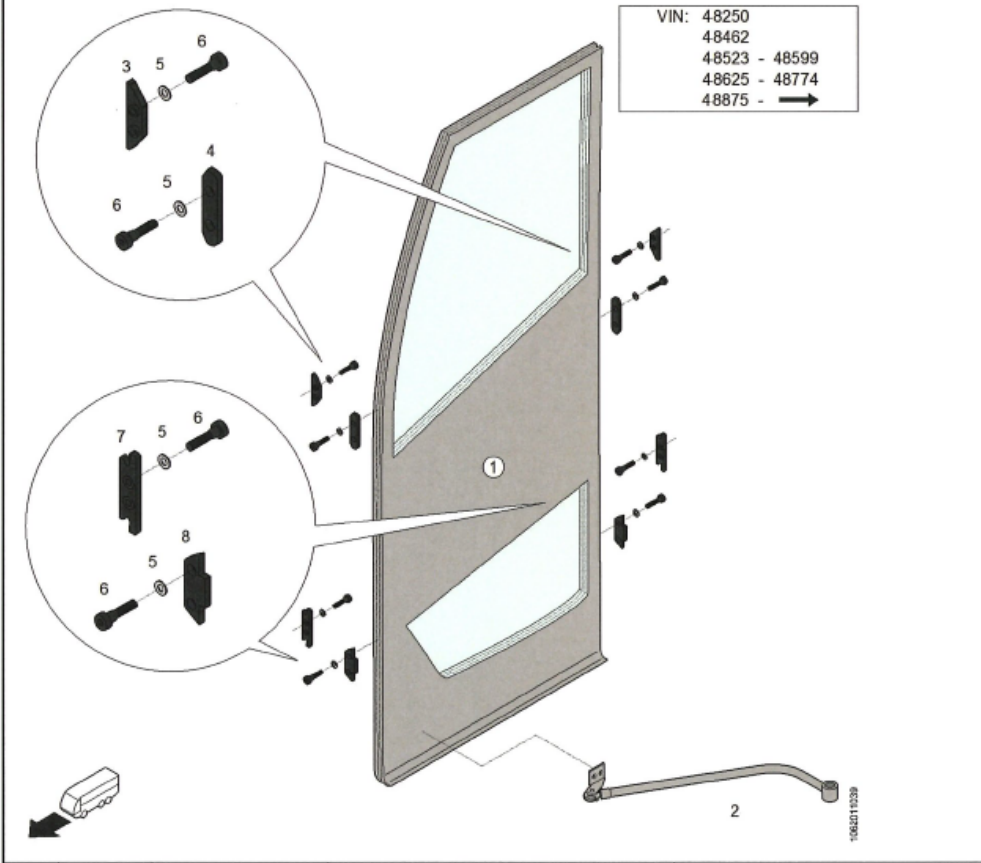

Pos.	Q.	Part n°	Description	Specification
1	1	11383292	Door panel, without accessories	
2	1	11383304	Bar + accessories	
3	2	11088692	Catch	
4	2	11099602	Catch	
5	8	660638614	Coil spring lock washer	DIN 137B Ø8,4xØ15x0,8mm
6	8	660292107	Screw	DIN 7984 M8x1,25x30 k.=8.8
7	2	11088688	Catch	
8	2	11099601	Catch	

Passenger door 1: door rubbers

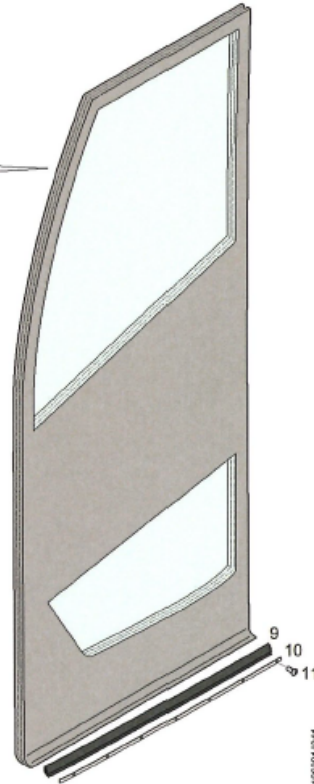
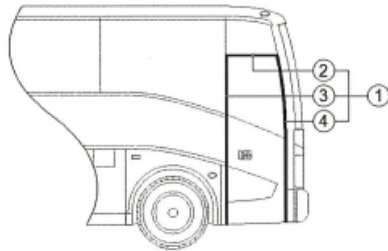
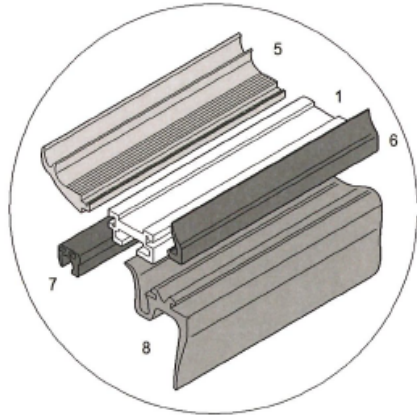

VIN: 48250
48462
48523 - 48599
48625 - 48774
48875 - →

Pos.	Q.	Part n°	Description	Specification
1	1	11383297	Aluminium sections	DIN 966 M5x12 MAT:IN
2	*1	11462023	Aluminium section	
3	*1	11462027	Aluminium section	
4	*1	11462026	Aluminium section	
5	#m	11436110	Rubber section	
6	1	10670195	Rubber section	
7	1	11383311	Sensitive edge	
8	1	11383307	Rubber section	
9	1	10706810	Rubber section	
10	1	11286468	Aluminium section	
11	7	11052696	Screw	

CER 2. Request for Pre-Offer Change or Approved Equal

This form must be used for requested clarifications, changes, substitutes or approval of items equal to items specified with a brand name and must be submitted as far in advance of the Due Date, as specified in “Questions, Clarifications and Omissions.”

**Shasta Regional Transportation Agency
 Procurement No. 2019-01
 Battery Electric Vehicle Procurement for Salmon Runner and North Valley Feeder**

Request #: 02 Proposer: ABC Bus, Inc. RFP Section: TS 89.2 Bicycle Racks Page: 152	
Questions/clarification or approved equal: Would you accept a bicycle rack that is mounted at the rear of the coach with a capacity to hold 5 bicycles.	
Agency action:	<input type="checkbox"/> Approved <input type="checkbox"/> Denied <input type="checkbox"/> See addendum <input checked="" type="checkbox"/> See response below
Agency response: SRTA requires the ability to safely and easily store up to four bikes. Bicycle storage must be secure and minimize damage to bicycles. The process to load bicycles must be easy and safe for passengers and driver. SRTA also requires luggage storage. While interior bicycle racks are preferred, it is not required. SRTA requests bidders propose a solution for bicycles and luggage that best meets SRTA's requirements.	

CER 2. Request for Pre-Offer Change or Approved Equal

Request #: 02 (Attachment)

